

Approval body for construction products  
and types of construction

Bautechnisches Prüfamt

An institution established by the Federal and  
Laender Governments



## European Technical Assessment

**ETA-12/0038**  
**of 1 June 2022**

English translation prepared by DIBt - Original version in German language

### General Part

Technical Assessment Body issuing the  
European Technical Assessment:

Deutsches Institut für Bautechnik

Trade name of the construction product

Screws Twin UD and PIR-FIX

Product family  
to which the construction product belongs

Screws for use in timber constructions

Manufacturer

SFS Group Schweiz AG  
Rosenbergsaustasse 10  
CH - 9435 Heerbrugg  
SCHWEIZ

Manufacturing plant

HECO-Schrauben GmbH & Co. KG  
Dr. Kurt-Steim-Straße 28  
78713 Schramberg

S.C. HECO Schrauben S.R.L.  
Str. Laminoristilor Nr. 159  
RO-405100 Campia Turzii

This European Technical Assessment  
contains

22 pages including 4 annexes which form an integral part  
of this assessment

This European Technical Assessment is  
issued in accordance with Regulation (EU)  
No 305/2011, on the basis of

EAD 130118-01-0603 – SCREWS AND THREADED  
RODS IN TIMBER STRUCTURES

This version replaces

ETA-12/0038 issued on 7 August 2018

The European Technical Assessment is issued by the Technical Assessment Body in its official language. Translations of this European Technical Assessment in other languages shall fully correspond to the original issued document and shall be identified as such.

Communication of this European Technical Assessment, including transmission by electronic means, shall be in full. However, partial reproduction may only be made with the written consent of the issuing Technical Assessment Body. Any partial reproduction shall be identified as such.

This European Technical Assessment may be withdrawn by the issuing Technical Assessment Body, in particular pursuant to information by the Commission in accordance with Article 25(3) of Regulation (EU) No 305/2011.

## Specific Part

### 1 Technical description of the product

The Twin UD and PIR-FIX screws are self-tapping screws made from special carbon steel. They have a corrosion protection according to Annex A.2.6. The outer thread diameter of the threaded part close to the head is 8.8 mm and 7.5 mm in the threaded part close to the tip. The overall length of the screws is ranging from 170 mm to 600 mm (nominal dimension). Further dimensions are shown in Annex 4.

All screws achieve a bending angle  $\alpha$  of at least  $45/d^{0.7} + 20$ , where  $d$  is the outer thread diameter of the screws.

### 2 Specification of the intended use in accordance with the applicable European Assessment Document

The performances given in Section 3 are only valid if the screws are used in compliance with the specifications and conditions given in Annex 1 and 2.

Durability is only ensured if the specifications of intended use according to Annex 1 and 2 are taken into account.

The verifications and assessment methods on which this European Technical Assessment is based lead to the assumption of a working life of the screws of at least 50 years. The indications given on the working life cannot be interpreted as a guarantee given by the producer, but are to be regarded only as a means for choosing the right products in relation to the expected economically reasonable working life of the works.

### 3 Performance of the product and references to the methods used for its assessment

#### 3.1 Mechanical resistance and stability (BWR 1)

Essential characteristic	Performance
Dimensions	See Annex 4
Characteristic yield moment	See Annex 2
Bending angle	See Annex 2
Characteristic withdrawal parameter	See Annex 2
Characteristic head pull-through parameter	See Annex 2
Characteristic tensile strength	See Annex 2
Characteristic yield strength	See Annex 3
Characteristic torsional strength	See Annex 2
Insertion moment	See Annex 2
Spacings, end and edge distances of the screws and minimum thickness of the wood-based material	See Annex 2
Slip modulus for mainly axially loaded screws	See Annex 2
Durability against corrosion	See Annex 2

**3.2 Safety in case of fire (BWR 2)**

Essential characteristic	Performance
Reaction to fire	Class A1

**3.3 Safety and accessibility in use (BWR 4)**

Same as BWR 1.

**4 Assessment and verification of constancy of performance (AVCP) system applied, with reference to its legal base**

In accordance with EAD No. 130118-01-0603 the applicable European legal act is: 97/176/EC.

The system to be applied is: 3

**5 Technical details necessary for the implementation of the AVCP system, as provided for in the applicable EAD**

Technical details necessary for the implementation of the AVCP system are laid down in the control plan deposited with Deutsches Institut für Bautechnik.

Issued in Berlin on 1 June 2022 by Deutsches Institut für Bautechnik

Anja Dewitt  
Head of Section

*beglaubigt:*  
Blümel

## Annex 1 Specifications of intended use

### A.1.1 Use of Twin UD and PIR-FIX screws only for:

- static and quasi-static loads

### A.1.2 Connection materials

The screws are used for connections in load bearing timber structures between timber members or between timber members and steel members:

- Solid timber (softwood) in accordance with EN 14081-1<sup>1</sup>,
- Glued laminated timber in accordance with EN 14080<sup>2</sup>,
- Glued solid timber in accordance with EN 14080,
- Laminated veneer lumber LVL (softwood) in accordance with EN 14374<sup>3</sup>,
- Cross laminated timber (softwood) in accordance with European Technical Assessments.

The screws are used for connecting the following wood-based panels to the timber members mentioned above:

- Oriented strand boards (OSB) in accordance with EN 300<sup>4</sup> and EN 13986,
- Plywood in accordance with EN 636<sup>5</sup> and EN 13986<sup>6</sup>,
- Particleboards in accordance with EN 312<sup>7</sup> and EN 13986,
- Cement-bonded particleboards in accordance with EN 634-2<sup>8</sup> and EN 13986,
- Fibreboards in accordance with EN 622-2<sup>9</sup>, EN 622-3<sup>10</sup> and EN 13986,
- Solid wood panels (SWP) in accordance with EN 13353<sup>11</sup> and EN 13986.

Wood-based panels are only arranged on the side of the screw head.

The Twin UD and PIR-FIX screws may be used for the fixing of thermal insulation material on top of rafters or on wood-based members in vertical façades.

1	EN 14081-1:2005+A1:2011	Timber structures – Strength graded structural timber with rectangular cross section – Part 1: General requirements
2	EN 14080:2013	Timber structures – Glued laminated timber and glued solid timber – Requirements
3	EN 14374:2004	Timber structures – Structural laminated veneer lumber – Requirements
4	EN 300:2006	Oriented strand boards (OSB) – Definition, classification and specifications
5	EN 636:2012+A1:2015	Plywood – Specifications
6	EN 13986:2004+A1:2015	Wood-based panels for use in construction – Characteristics, evaluation of conformity and marking
7	EN 312:2010	Particleboards – Specifications
8	EN 634-2:2007	Cement-bonded particleboards – Specifications – Part 2: Requirements for OPC bonded particleboards for use in dry, humid and external conditions
9	EN 622-2:2004/AC:2005	Fibreboards – Specifications – Part 2: Requirements for hardboards
10	EN 622-3:2004	Fibreboards – Specifications – Part 3: Requirements for medium boards
11	EN 13353:2008+A1:2011	Solid wood panels (SWP) – Requirements

Screws Twin UD and PIR-FIX	Annex 1.1
Specifications of intended use	

### A.1.3 Use Conditions (environmental conditions)

The corrosion protection of Twin UD and PIR-FIX screws is specified in Annex A.2.6.

### A.1.4 Installation provisions

EN 1995-1-1<sup>12</sup> applies for the installation of Twin UD and PIR-FIX screws.

A minimum of two screws is used for connections in load-bearing timber structures.

The screws are driven into the wood-based member made of softwood without pre-drilling. Deviating from this provision the screws may be driven into counter battens in pre-drilled holes with a diameter of 5.0 mm.

In the case of fastening counter battens on thermal insulation material on top of rafters the screws are driven in the rafter through the counter battens and the thermal insulation material without pre-drilling in one sequence.

The screw holes in steel members are pre-drilled with an adequate diameter greater than the outer thread diameter.

The solid timber, glued laminated timber, glued solid timber, laminated veneer lumber and cross laminated timber are from spruce, pine or fir.

<sup>12</sup> EN 1995-1-1:2004/AC:2006 Eurocode 5: Design of timber structures – Part 1-1: General – Common rules and rules for buildings +A1:2008+A2:2014

Screws Twin UD and PIR-FIX	Annex 1.2
Installation provisions	

## Annex 2 Characteristic values of the load-carrying capacities

Table A.2.1 Characteristic load-carrying capacities of Twin UD and PIR-FIX screws

Outer thread diameter [mm]		Twin UD and PIR-FIX
		7.5
Characteristic yield moment $M_{y,k}$ [Nm]		13.0
Characteristic tensile strength $f_{tens,k}$ [kN]		12.0
Characteristic torsional strength $f_{tor,k}$ [Nm]	Thread close to the head	23.0
	Thread close to the tip	13.0

### A.2.1 General

The Twin UD and PIR-FIX screws achieve a bending angle  $\alpha$  of at least  $45/d^{0.7} + 20$ , where  $d$  is the outer thread diameter of the screws.

The minimum penetration length of the threaded part of the screws in the wood-based members  $l_{ef}$  is:

$$l_{ef} = \frac{4 \cdot d}{\sin \alpha} \quad (2.1)$$

Where

$\alpha$  angle between screw axis and grain direction [°],

$d$  outer thread diameter of the screw.

The inner thread diameter  $d_1$  of the screws is greater than the maximal width of the gaps in the layer of cross laminated timber.

### A.2.2 Laterally loaded screws

The outer thread diameter  $d$  is used as effective diameter of the screw in accordance with EN 1995-1-1.

The embedding strength for the screws in wood-based members or in wood-based panels are taken from EN 1995-1-1, unless otherwise specified in the following.

### A.2.3 Axially loaded screws

#### A.2.3.1 Slip modulus for mainly axially loaded screws

The axial slip modulus  $K_{ser}$  of the threaded part of a screw for the serviceability limit state is taken independent of angle  $\alpha$  to the grain as:

$$K_{ser} = 780 \cdot d^{0.2} \cdot l_{ef}^{0.4} \quad [\text{N/mm}] \quad (2.2)$$

Where

$d$  outer thread diameter of the screw [mm],

$l_{ef}$  penetration length of the threaded part of the screw in the wood-based member [mm].

Screws Twin UD and PIR-FIX	Annex 2.1
Characteristic values of the load-carrying capacities	

### A.2.3.2 Axial withdrawal capacity – Characteristic withdrawal parameter

The characteristic withdrawal parameter of Twin UD and PIR-FIX screws at an angle  $\alpha = 90^\circ$  to the grain based on a characteristic density of the wood-based member  $\rho_a$  of  $350 \text{ kg/m}^3$  is:

$$f_{ax,k} = 12.5 \text{ N/mm}^2.$$

For LVL a maximum characteristic density of  $500 \text{ kg/m}^3$  shall be used in equation (8.40a) of EN 1995-1-1.

For screws penetrating more than one layer of cross laminated timber the different layers may be taken into account proportionally. In the narrow faces of the cross laminated timber the screws are fully inserted in one layer.

The characteristic withdrawal parameter of the wood-based panels mentioned below at an angle  $\alpha = 90^\circ$  is  $f_{ax,k} = 10.0 \text{ N/mm}^2$  for Twin UD and PIR-FIX screws:

- Plywood in accordance with EN 636 and EN 13986 with a characteristic density of at least  $400 \text{ kg/m}^3$ ,
- Particleboards in accordance with EN 312 and EN 13986 of at least technical class P4,
- OSB/3 and OSB/4 in accordance with EN 300 and EN 13986.

### A.2.3.3 Head pull-through capacity – Characteristic head pull-through parameter

For Twin UD and PIR-FIX screws the withdrawal capacity of the thread in the wood-based member with the screw head can be taken into account.

### A.2.4 Spacings, end and edge distances of the screws and minimum thickness of the wood-based material

Minimum thickness for structural members is  $t = 30 \text{ mm}$ .

#### A.2.4.1 Laterally or laterally and axially loaded screws

##### **Screws in pre-drilled holes in counter battens**

Pre-drilling is only allowed in counter battens. For Twin UD and PIR-FIX screws in pre-drilled holes in counter battens the minimum spacings, end and edge distances are given in EN 1995-1-1, clause 8.3.1.2 and Table 8.2 as for nails in pre-drilled holes. Here, the outer thread diameter  $d$  of the thread close to the head shall be considered.

##### **Screws in non pre-drilled holes**

For Twin UD and PIR-FIX screws minimum spacings, end and edge distances are given in EN 1995-1-1, clause 8.3.1.2 and Table 8.2 as for nails in non-predrilled holes. Here, the outer thread diameter  $d$  of the thread close to the head or the tip, respectively, shall be considered.

For Douglas fir members minimum spacings and distances parallel to the grain shall be increased by 50 %.

Minimum distances from loaded or unloaded ends parallel to the grain shall be at least  $15 \cdot d$  for timber thickness  $t < 5 \cdot d$ .

#### A.2.4.2 Only axially loaded screws

For Twin UD and PIR-FIX screws the minimum spacings, end and edge distances are given in EN 1995-1-1, clause 8.3.1.2 and Table 8.2 as for nails in non-predrilled holes and clause 8.7.2 and Table 8.6.

Screws Twin UD and PIR-FIX	Annex 2.2
Characteristic values of the load-carrying capacities, spacings, end and edge distances and dimensions	



### A.2.5 Insertion moment

The ratio between the characteristic torsional strength  $f_{tor,k}$  and the mean value of insertion moment  $R_{tor,mean}$  fulfills the requirement for all screws.

### A.2.6 Durability against corrosion

Screws made from carbon steel have the coatings in accordance with Table A.2.3

Table A.2.3 Coatings of the Twin UD and PIR-FIX screws

Coating		Minimum thickness of the coating [ $\mu\text{m}$ ]
Durocoat	DP1	5
	T	
	WB	
Electrolytically galvanised		5
Hot dip zinc coating		55
Zinc-nickel coating (HP coating)		5

Screws Twin UD and PIR-FIX	Annex 2.3
Insertion moment and durability against corrosion	

## Annex 3 Fastening of thermal insulation material on top of rafters

### A.3.1 General

The Twin UD and PIR-FIX screws may be used for the fixing of thermal insulation material on top of rafters or on wood-based members in vertical façades. In the following, the meaning of the word rafter includes wood-based members with inclinations between 0° and 90°.

The thickness of the thermal insulation material is up to 400 mm. Thermal insulation material is used, which is applicable as insulation on top of rafters or on wood-based members in vertical façades.

The counter battens are from solid timber (softwood) in accordance with EN 14081-1. The minimum thickness  $t$  and the minimum width  $b$  of the counter battens are given in Table A.3.1:

Table A.3.1 Minimum thickness and minimum width of the counter battens

Outer thread diameter $d$ [mm]	Minimum thickness $t$ [mm]	Minimum width $b$ [mm]
7.5	40	60

Instead of counter battens the wood-based panels specified in chapter A.3.2.1 may be used.

The minimum width of the rafters is 60 mm.

The spacing between screws is not more than 1.75 m.

Friction forces are not considered for the design of the characteristic withdrawal capacity of the screws.

The anchorage of wind suction forces of the counter battens shall be considered for design. Screws perpendicular to the grain of the rafter are arranged, where required.

### A.3.2 Parallel inclined screws and thermal insulation material in compression

#### A.3.2.1 Mechanical model

The system of rafter, thermal insulation material on top of rafter and counter battens parallel to the rafter can be considered as a beam on elastic foundation. The counter batten represents the beam, and the thermal insulation material on top of the rafter the elastic foundation. The minimum compressive stress of the thermal insulation material at 10 % deformation, measured in accordance with EN 826<sup>13</sup>, shall be  $\sigma_{10\%} = 0.05 \text{ N/mm}^2$ . The counter batten is loaded perpendicular to the axis by point loads  $F_b$ . Further point loads  $F_s$  are caused by the shear load of the roof due to dead and snow load, which are transferred from the screw heads into the counter battens.

Instead of counter battens the following wood-based panels may be used to cover the thermal insulation material if they are suitable for that use:

- Oriented strand boards (OSB) in accordance with EN 300 and EN 13986,
- Plywood in accordance with EN 636 and EN 13986,
- Particleboards in accordance with EN 312 and EN 13986,
- Fibreboards in accordance with EN 622-2, EN 622-3 and EN 13986,
- Laminated veneer lumber in accordance with EN 14374.

The minimum thickness of the wood-based panels is 22 mm.

The word counter batten includes the meaning of wood-based panels mentioned above in the following.

Screws Twin UD and PIR-FIX	Annex 3.1
Fastening of thermal insulation material on top of rafters	

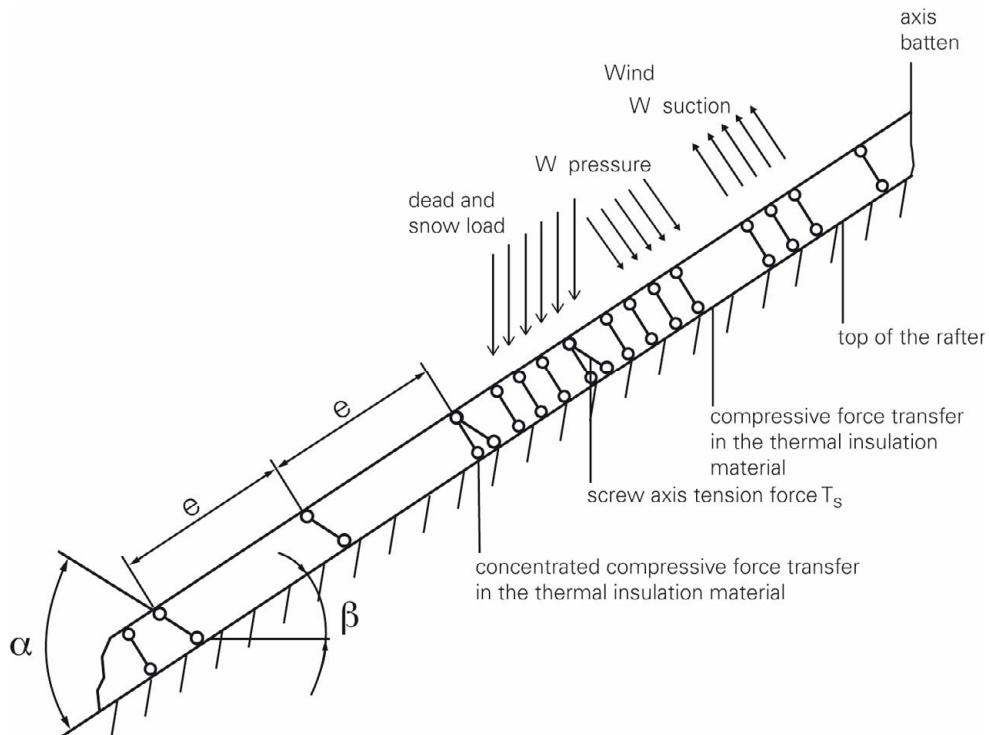
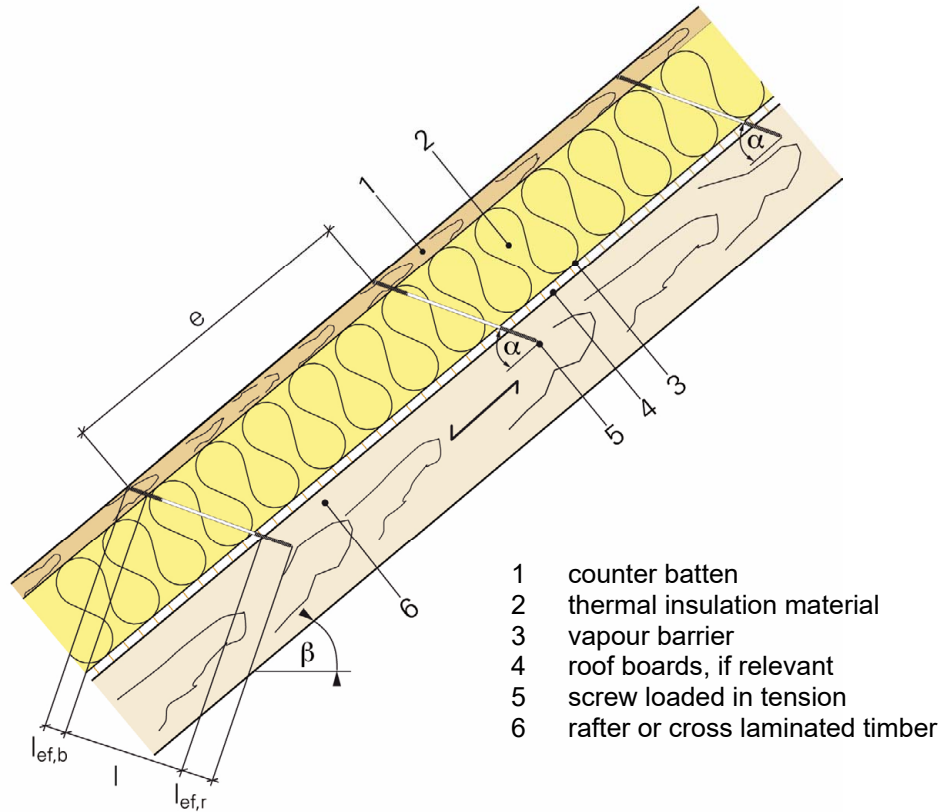

Figure A.3.1 Fastening of the thermal insulation material on top of rafters – Structural system of parallel arranged screws

Electronic copy of the ETA by DIBt: ETA-12/0038

Screws Twin UD and PIR-FIX	Annex 3.2
Fastening of thermal insulation material on top of rafters	

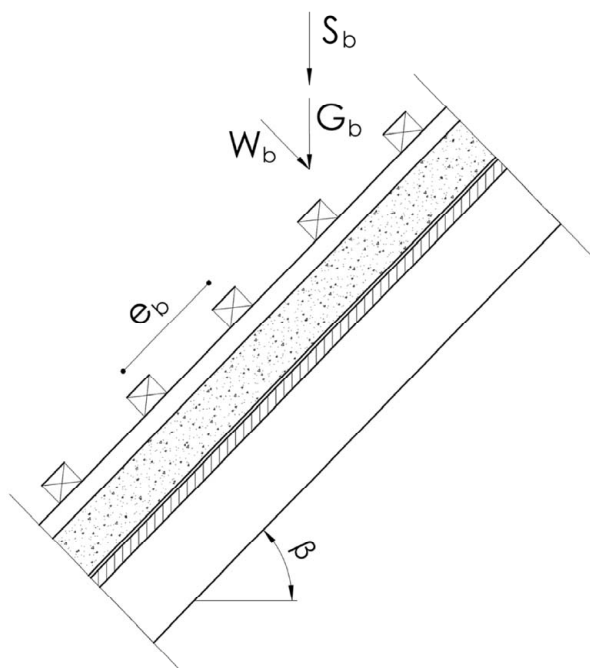

Figure A.3.2 Point loads  $F_b$  perpendicular to the counter battens

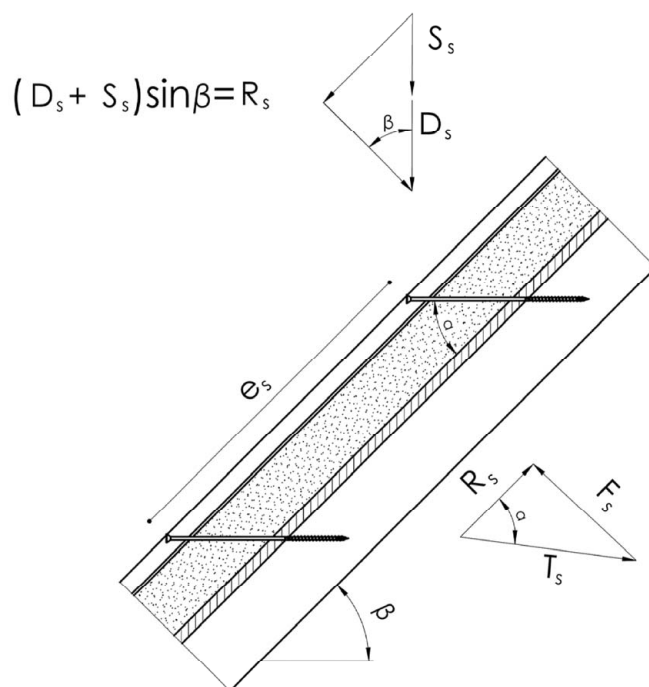

Figure A.3.3 Point loads  $F_s$  perpendicular to the counter battens, load application in the area of the screw heads

Electronic copy of the ETA by DIBt: ETA-12/0038

Screws Twin UD and PIR-FIX	Annex 3.3
Fastening of thermal insulation material on top of rafters	

### A.3.2.2 Design of the counter battens

It is assumed that the spacing between the counter battens exceeds the characteristic length  $l_{char}$ .

The characteristic values of the bending stresses may be calculated as:

$$M_k = \frac{(F_{b,k} + F_{s,k}) \cdot l_{char}}{4} \quad (3.1)$$

Where

$$l_{char} \quad \text{characteristic length } l_{char} = \sqrt[4]{\frac{4 \cdot EI}{w_{ef} \cdot K}} \quad (3.2)$$

$EI$  bending stiffness of the counter batten,

$K$  modulus of subgrade reaction,

$w_{ef}$  effective width of the thermal insulation material,

$F_{b,k}$  point loads perpendicular to the counter battens,

$F_{s,k}$  point loads perpendicular to the counter battens, load application in the area of the screw heads.

The modulus of subgrade reaction  $K$  may be calculated from the modulus of elasticity  $E_{HI}$  and the thickness  $t_{HI}$  of the thermal insulation material if the effective width  $w_{ef}$  of the thermal insulation material under compression is known. Due to the load extension in the thermal insulation material the effective width  $w_{ef}$  is greater than the width of the counter batten or rafter, respectively. For further calculations, the effective width  $w_{ef}$  of the thermal insulation material may be determined as:

$$w_{ef} = w + t_{HI} / 2 \quad (3.3)$$

Where

$w$  minimum from width of the counter batten or rafter, respectively,

$t_{HI}$  thickness of the thermal insulation material.

$$K = \frac{E_{HI}}{t_{HI}} \quad (3.4)$$

The following condition shall be satisfied:

$$\frac{\sigma_{m,d}}{f_{m,d}} = \frac{M_d}{W \cdot f_{m,d}} \leq 1 \quad (3.5)$$

For the calculation of the section modulus  $W$  the net cross section shall be considered.

The characteristic values of the shear stresses shall be calculated as:

$$V_k = \frac{(F_{b,k} + F_{s,k})}{2} \quad (3.6)$$

The following condition shall be satisfied:

$$\frac{\tau_d}{f_{v,d}} = \frac{1.5 \cdot V_d}{A \cdot f_{v,d}} \leq 1 \quad (3.7)$$

For the calculation of the cross section area the net cross section shall be considered.

Screws Twin UD and PIR-FIX	Annex 3.4
Fastening of thermal insulation material on top of rafters	

### A.3.2.3 Design of the thermal insulation material

The characteristic value of the compressive stresses in the thermal insulation material may be calculated as:

$$\sigma_k = \frac{1.5 \cdot F_{b,k} + F_{s,k}}{2 \cdot l_{char} \cdot W} \quad (3.8)$$

The design value of the compressive stress shall not be greater than 110 % of the compressive strength at 10 % deformation calculated in accordance with EN 826.

### A.3.2.4 Design of the screws

The screws are loaded predominantly axial. The characteristic value of the axial tension force in the screw may be calculated from the shear loads of the roof  $R_s$ :

$$T_{S,k} = \frac{R_{S,k}}{\cos \alpha} \quad (3.9)$$

The load-carrying capacity of axially loaded screws is the minimum design value of the axial withdrawal capacity of the threaded part of the screw, the head pull-through capacity of the screw and the tensile capacity of the screw in accordance with Annex 2.

In order to limit the deformation of the screw head for thermal insulation material with thickness over 220 mm or with compressive strength below 0.12 N/mm<sup>2</sup>, respectively, the axial withdrawal capacity of the screws shall be reduced by the factors  $k_1$  and  $k_2$ :

$$F_{ax,\alpha,Rd} = \min \left\{ \frac{f_{ax,d} \cdot d \cdot l_{ef,r} \cdot k_1 \cdot k_2}{1.2 \cdot \cos^2 \alpha + \sin^2 \alpha} \cdot \left( \frac{\rho_k}{350} \right)^{0.8}; \frac{f_{ax,d} \cdot d \cdot l_{ef,b}}{1.2 \cdot \cos^2 \alpha + \sin^2 \alpha} \cdot \left( \frac{\rho_k}{350} \right)^{0.8}; \frac{f_{tens,k}}{\gamma_{M2}} \right\} \quad (3.10)$$

Where

- $f_{ax,d}$  design value of the withdrawal parameter of the threaded part of the screw [N/mm<sup>2</sup>],  $f_{ax,d} = k_{mod} \cdot f_{ax,k} / \gamma_M$
- $f_{ax,k}$  characteristic value of the withdrawal parameter of the threaded part of the screw [N/mm<sup>2</sup>],
- $k_{mod}$  modification factor for duration of load and moisture content in accordance with EN 1995-1-1,
- $\gamma_M$  partial factor for material properties in accordance with EN 1995-1-1,
- $d$  outer thread diameter of the screw [mm],
- $l_{ef,r}$  penetration length of the threaded part of the screw in the rafter [mm],  $l_{ef} \geq 40$  mm
- $l_{ef,b}$  penetration length of the threaded part of the screw in the counter batten or wood-based panel [mm],
- $\rho_k$  characteristic density of the wood-based member [kg/m<sup>3</sup>], for wood-based panels  $\rho_k = 350$  kg/m<sup>3</sup>, for LVL  $\rho_k \leq 500$  kg/m<sup>3</sup>,
- $\alpha$  angle  $\alpha$  between screw axis and grain direction,  $30^\circ \leq \alpha \leq 90^\circ$ ,
- $f_{tens,k}$  characteristic tensile capacity of the screw in accordance with Annex 2 [N],
- $\gamma_{M2}$  partial factor in accordance with EN 1993-1-1<sup>14</sup>,
- $k_1$   $\min \{1; 220/t_{HI}\}$
- $k_2$   $\min \{1; \sigma_{10\%}/0.12\}$
- $t_{HI}$  thickness of the thermal insulation material [mm],
- $\sigma_{10\%}$  compressive stress of the thermal insulation material under 10 % deformation [N/mm<sup>2</sup>].

If equation (3.10) is fulfilled, the deflection of the counter battens does not need to be considered when designing the load-carrying capacity of the screws.

<sup>14</sup> EN 1993-1-1:2005/AC:2009 Eurocode 3: Design of steel structures – Part 1-1: General rules and rules for buildings +A1:2014

Screws Twin UD and PIR-FIX	Annex 3.5
Fastening of thermal insulation material on top of rafters	

### A.3.3 Alternatively inclined screws and thermal insulation material not in compression

#### A.3.3.1 Mechanical model

Depending on the screw spacing and the arrangement of tensile and compressive screws with different inclinations the counter battens are loaded by significant bending moments. The bending moments are derived based on the following assumptions:

- The tensile and compressive loads in the screws are determined based on equilibrium conditions from the actions parallel and perpendicular to the roof plane. These actions are constant line loads  $q_{\perp}$  and  $q_{\parallel}$ .
- The screws act as hinged columns supported 10 mm within the counter batten or rafter, respectively. The effective column length consequently equals the length of the screws between counter batten and rafter plus 20 mm.
- The counter batten is considered as a continuous beam with a constant span  $\ell = A + B$ . The compressive screws constitute the supports of the continuous beam while the tensile screws transfer concentrated loads perpendicular to the counter batten axis.

The screws are predominantly loaded in withdrawal or compression, respectively. The characteristic values of the screw's normal forces are determined based on the loads parallel and perpendicular to the roof plane:

$$\text{Compressive screw: } N_{c,k} = (A+B) \cdot \left( -\frac{q_{\parallel,k} \cdot \sin \alpha_2 + q_{\perp,k} \cdot \cos \alpha_2}{\sin(\alpha_1 + \alpha_2)} \right) \quad (3.11)$$

$$\text{Tensile screw: } N_{t,k} = (A+B) \cdot \left( \frac{q_{\parallel,k} \cdot \sin \alpha_1 - q_{\perp,k} \cdot \cos \alpha_1}{\sin(\alpha_1 + \alpha_2)} \right) \quad (3.12)$$

A distance of the screws in accordance with Figure 3.5,

B distance of the alternatively inclined screws in accordance with Figure 3.5,

$q_{\parallel,k}$  characteristic value of the loads parallel to the roof plane,

$q_{\perp,k}$  characteristic value of the loads perpendicular to the roof plane,

$\alpha$  angle  $\alpha_1$  and  $\alpha_2$  between screw axis and grain direction,  $30^\circ \leq \alpha_1 \leq 90^\circ$ ,  $30^\circ \leq \alpha_2 \leq 90^\circ$ .

The bending moments in the counter batten follow from the constant line load  $q_{\perp}$  and the load components perpendicular to the counter batten from the tensile screws. The span of the continuous beam is  $(A + B)$ . The characteristic value of the load component perpendicular to the counter batten from the tensile screw is:

$$F_{zs,k} = (A+B) \cdot \left( \frac{q_{\parallel,k} \cdot \sin \alpha_1 \cdot \sin \alpha_2 - q_{\perp,k} \cdot \cos \alpha_1 \cdot \sin \alpha_2}{\sin(\alpha_1 + \alpha_2)} \right) \quad (3.13)$$

A positive value for  $F_{zs,k}$  means a load towards the rafter, a negative value a load away from the rafter. The system of the continuous beam is shown in Figure 3.5.

The counter battens or wood-based panels fixed on the rafter shall be supported perpendicular to the load-bearing plane.

Screws Twin UD and PIR-FIX	Annex 3.6
Fastening of the thermal insulation material on top of rafters	

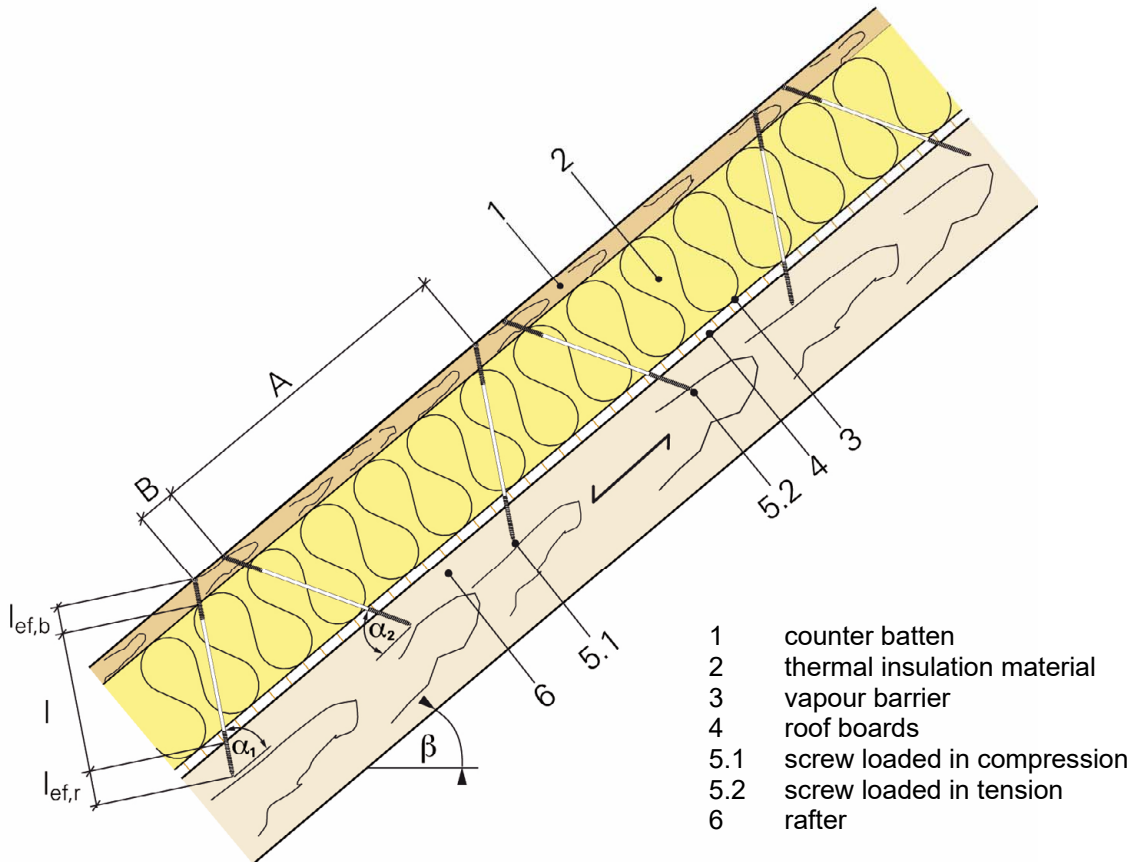

Figure 3.4 Fastening of thermal insulation material on top of rafters – Structural system for alternatively inclined screws and continuous counter batten under constant line loads from actions on the roof plane  $q_{\perp}$  and concentrated loads from tensile screws  $F_{zs}$

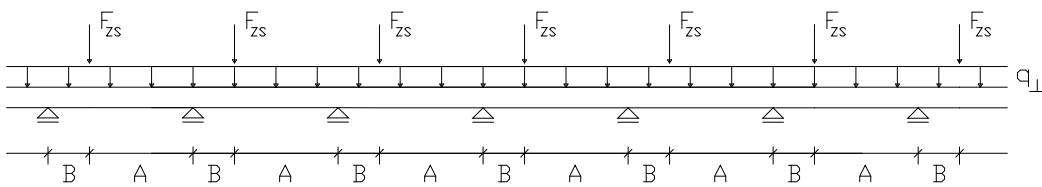

Figure 3.5 Continuous counter batten under constant line loads from actions on the roof plane  $q_{\perp}$  and concentrated loads from tensile screws  $F_{zs}$

Electronic copy of the ETA by DIBt: ETA-12/0038

Screws Twin UD and PIR-FIX	Annex 3.7
Fastening of the thermal insulation material on top of rafters	



### A.3.3.2 Design of the screws

The design value of the load-carrying capacity of the screws may be calculated with equation (3.14) and (3.15). Screws loaded in tension:

$$F_{ax,\alpha,Rd} = \min \left\{ \frac{f_{ax,d} \cdot d \cdot l_{ef,b}}{1.2 \cdot \cos^2 \alpha_2 + \sin^2 \alpha_2} \cdot \left( \frac{\rho_{b,k}}{350} \right)^{0.8}; \frac{f_{ax,d} \cdot d \cdot l_{ef,r}}{1.2 \cdot \cos^2 \alpha_2 + \sin^2 \alpha_2} \cdot \left( \frac{\rho_{r,k}}{350} \right)^{0.8}; \frac{f_{tens,k}}{\gamma_{M2}} \right\} \quad (3.14)$$

Screws loaded in compression:

$$F_{ax,\alpha,Rd} = \min \left\{ \frac{f_{ax,d} \cdot d \cdot l_{ef,b}}{1.2 \cdot \cos^2 \alpha_1 + \sin^2 \alpha_1} \cdot \left( \frac{\rho_{b,k}}{350} \right)^{0.8}; \frac{f_{ax,d} \cdot d \cdot l_{ef,r}}{1.2 \cdot \cos^2 \alpha_1 + \sin^2 \alpha_1} \cdot \left( \frac{\rho_{r,k}}{350} \right)^{0.8}; \frac{\kappa_c \cdot N_{pl,k}}{\gamma_{M1}} \right\} \quad (3.15)$$

Where

- $f_{ax,d}$  design value of the withdrawal parameter of the threaded part of the screw [N/mm<sup>2</sup>],  
 $f_{ax,d} = k_{mod} \cdot f_{ax,k} / \gamma_M$
- $f_{ax,k}$  characteristic value of the withdrawal parameter of the threaded part of the screw [N/mm<sup>2</sup>],
- $k_{mod}$  modification factor for duration of load and moisture content in accordance with EN 1995-1-1,
- $\gamma_M$  partial factor for material properties in accordance with EN 1995-1-1,
- $d$  outer thread diameter of the screw [mm],
- $l_{ef,b}$  penetration length of the threaded part of the screw in the counter batten [mm],
- $l_{ef,r}$  penetration length of the threaded part of the screw in the rafter [mm],  $l_{ef} \geq 40$  mm,
- $\rho_{b,k}$  characteristic density of the counter batten [kg/m<sup>3</sup>],
- $\rho_{r,k}$  characteristic density of the rafter [kg/m<sup>3</sup>],
- $\alpha$  angle  $\alpha_1$  or  $\alpha_2$  between screw axis and grain direction,  $30^\circ \leq \alpha_1 \leq 90^\circ$ ,  $30^\circ \leq \alpha_2 \leq 90^\circ$ ,
- $f_{tens,k}$  characteristic tensile capacity of the screw in accordance with Annex 2 [N],
- $\gamma_{M1}, \gamma_{M2}$  partial factor in accordance with EN 1993-1-1,
- $\kappa_c \cdot N_{pl,k}$  buckling capacity of the screw given in Table 3.2 [N].

Screws Twin UD and PIR-FIX	Annex 3.8
Fastening of the thermal insulation material on top of rafters	

Table 3.2 Characteristic load-carrying capacity of the screws  $\kappa_c \cdot N_{pl,k}$  in kN

Free screw length between counter batten and rafter [mm]	Twin UD and PIR-FIX screws
	Outer thread diameter d [mm]
	7.5 / 8.8
	$\kappa_c \cdot N_{pl,k}$ [kN]
≤ 100	10.1
120	8.3
140	6.8
160	5.7
180	4.8
200	4.1
220	3.5
240	3.0
260	2.7
280	2.3
300	2.1
320	1.9
340	1.7
360	1.5
380	1.4
400	1.3
420	1.2
440	1.1
460	1.0
480	0.9

Screws Twin UD and PIR-FIX	Annex 3.9
Fastening of the thermal insulation material on top of rafters	

English translation prepared by DIBt

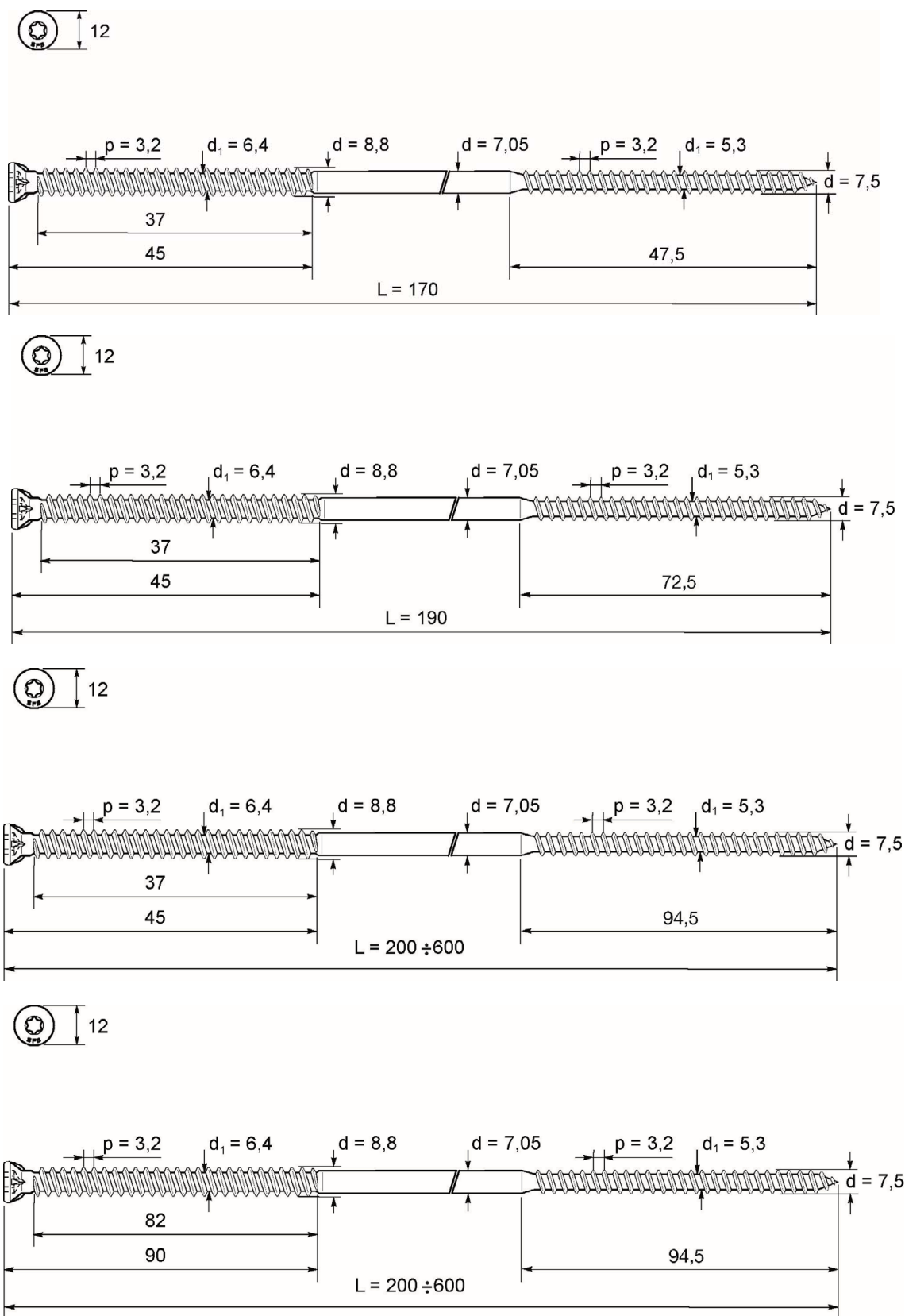

Electronic copy of the ETA by DIBt: ETA-12/0038

Screws Twin UD and PIR-FIX

Twin UD screws

Annex 4.1

### Alternative screw heads

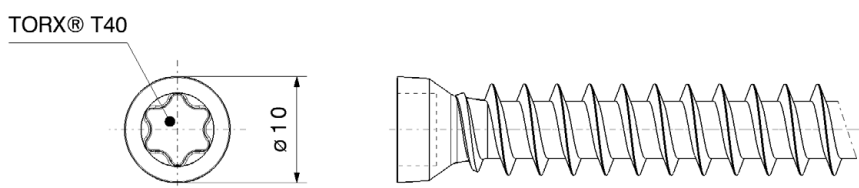
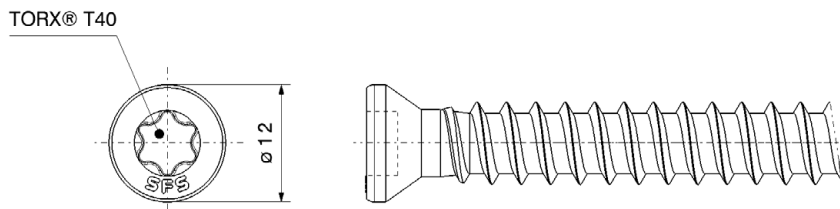

### Alternative screw tips

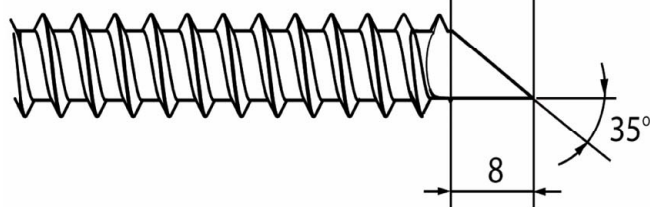

Screws Twin UD and PIR-FIX

Twin UD screws – Alternative screw heads and screw tips

Annex 4.2

### Alternative rough thread in the area of the shank

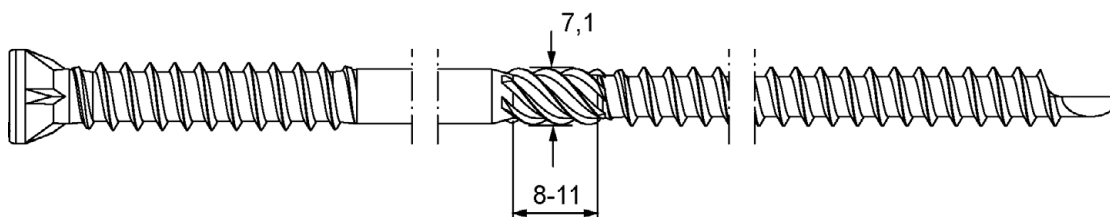

Screws Twin UD and PIR-FIX

Twin UD screws – Alternative rough thread in the area of the shank

Annex 4.3

English translation prepared by DIBt

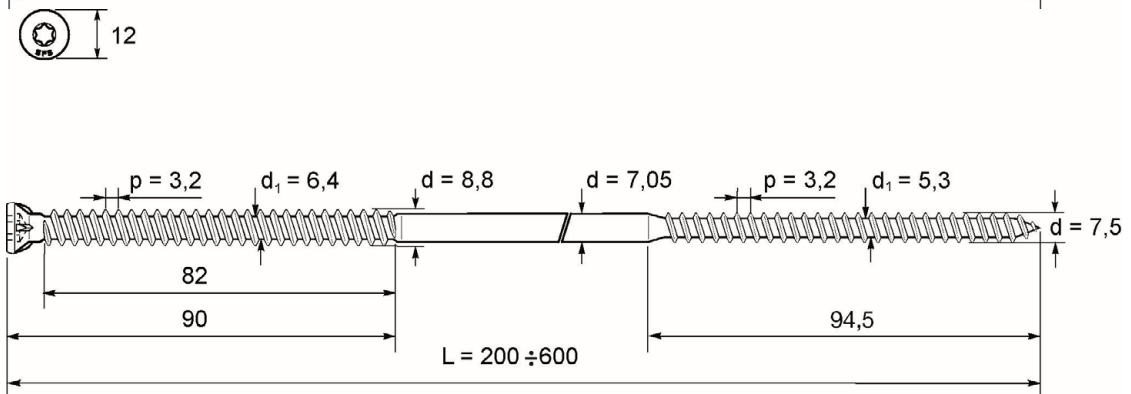
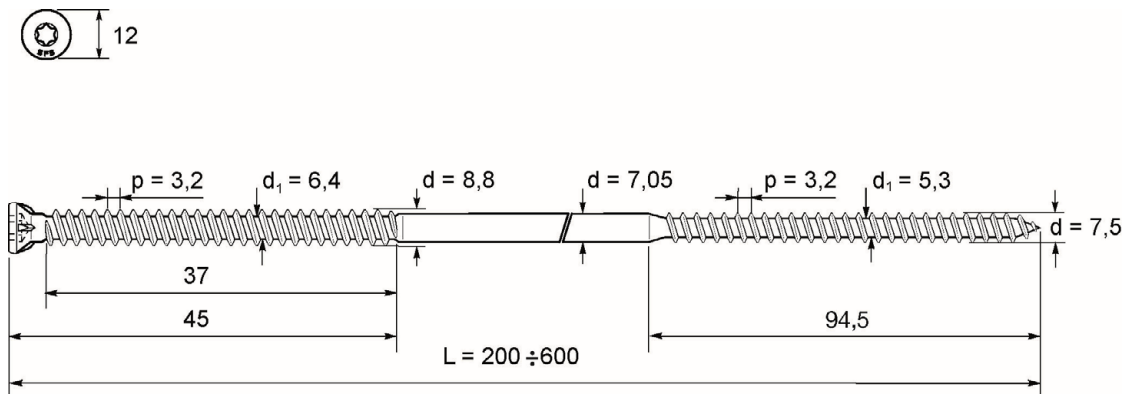
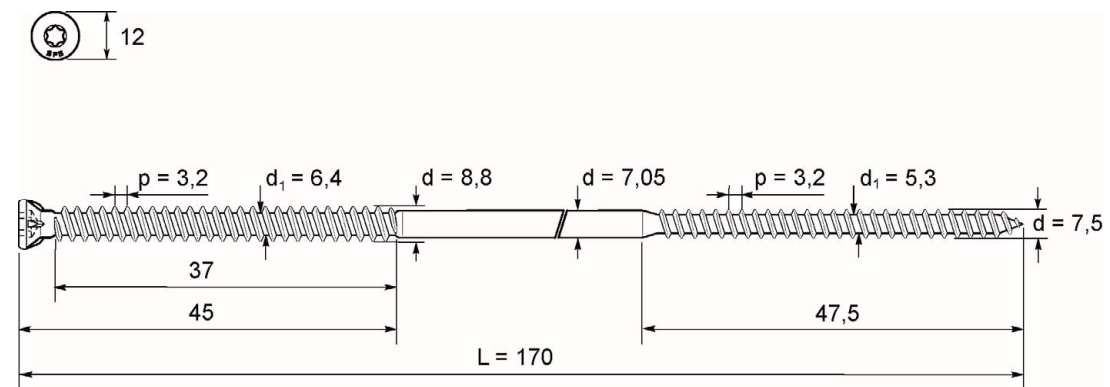
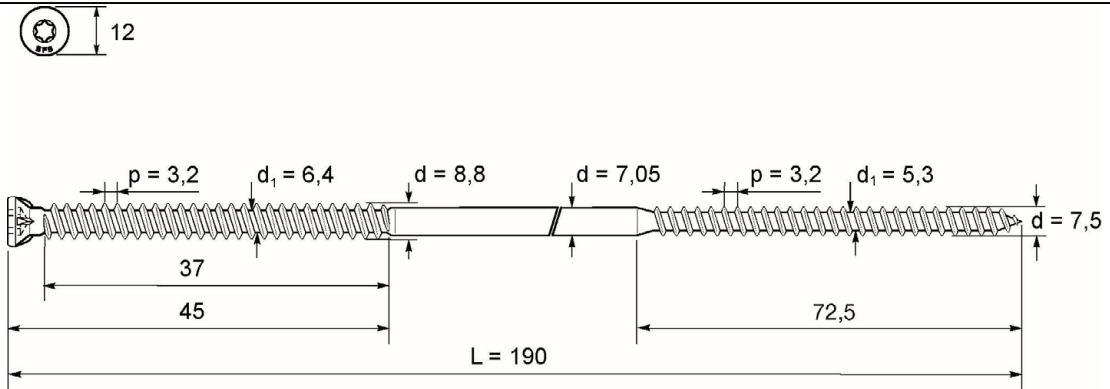

Alternative screw heads, screw tips and rough thread are similar to Twin UD screws

Screws Twin UD and PIR-FIX

PIR-FIX screws

Annex 4.4