



ETA-Danmark A/S
Göteborg Plads 1
DK-2150 Nordhavn
Tel. +45 72 24 59 00
Fax +45 72 24 59 04
Internet www.etadanmark.dk

Authorised and notified according
to Article 29 of the Regulation (EU)
No 305/2011 of the European
Parliament and of the Council of 9
March 2011

MEMBER OF EOTA



European Technical Assessment ETA-19/0129 of 2022/06/01

I General Part

Technical Assessment Body issuing the ETA and designated according to Article 29 of the Regulation (EU) No 305/2011: ETA-Danmark A/S

Trade name of the construction product:

SFS WB-T Threaded rod

Product family to which the above construction product belongs:

Threaded rod for use in timber constructions

Manufacturer:

SFS Group Schweiz AG
Rosenbergsaustrasse 10
CH-9435 Heerbrugg
Tel. +41 71 727 62 62
Internet www.sfs.biz

Manufacturing plant:

SFS intec AG, Division Construction
Manufacturing Plant 26

This European Technical Assessment contains:

15 pages including 4 annexes which form an integral part of the document

This European Technical Assessment is issued in accordance with Regulation (EU) No 305/2011, on the basis of:

European Assessment document (EAD) no. EAD 130118-01-0603 "Screws and threaded rods for timber constructions"

This version replaces:

The ETA with the same number issued on 2019-04-12

Translations of this European Technical Assessment in other languages shall fully correspond to the original issued document and should be identified as such.

Communication of this European Technical Assessment, including transmission by electronic means, shall be in full (excepted the confidential Annex(es) referred to above). However, partial reproduction may be made, with the written consent of the issuing Technical Assessment Body. Any partial reproduction has to be identified as such.

II SPECIFIC PART OF THE EUROPEAN TECHNICAL ASSESSMENT

1 Technical description of product and intended use

Technical description of the product

SFS WB-T threaded rods are used as screws for use in timber constructions. They shall be threaded over the full length. The rods shall be produced from carbon steel wire for nominal diameters of 16 mm or 20 mm. Where corrosion protection is required, the material or coating shall be declared in accordance with the relevant specification given in Annex A of EN 14592.

Geometry and Material

The nominal diameter (outer thread diameter), d , of SFS WB-T threaded rods shall not be less than 16 mm and shall not be greater than 20 mm. The overall length of the rods, ℓ , shall not be less than 64 mm ($d = 16$ mm) or 80 mm ($d = 20$ mm) and not be greater than 3000 mm. Other dimensions are given in Annex A.

The ratio of inner thread diameter to outer thread diameter d_i/d is 0,75.

The lead p (distance between two adjacent thread flanks) ranges from $0,31 \cdot d$ to $0,41 \cdot d$.

No breaking shall be observed at a bend angle, α , of less than $(45/d^{0,7} + 20)$ degrees.

2 Specification of the intended use in accordance with the applicable EAD

The threaded rods are used for connections in load bearing timber structures between members of solid timber (softwood), glued laminated timber (softwood), cross-laminated timber, and laminated veneer lumber (softwood) or similar glued members. SFS WB-T threaded rods are also used as tensile or compressive reinforcement perpendicular to the grain or as shear reinforcement in softwood members.

The threaded rods are intended to be used in timber connections for which requirements for mechanical resistance and stability and safety in use in the the sense of the Basic Works Requirements 1 and 4 of Regulation 305/2011 (EU) shall be fulfilled.

The design of the connections shall be based on the characteristic load-carrying capacities of the rods. The design capacities shall be derived from the characteristic capacities in accordance with Eurocode 5 or an appropriate national code.

The threaded rods are intended for use for connections subject to static or quasi static loading.

The zinc-coated threaded rods are for use in timber structures subject to the dry, internal conditions defined by the service classes 1 and 2 of EN 1995-1-1:2008 (Eurocode 5).

The provisions made in this European Technical Assessment are based on an assumed intended working life of the threaded rods of 50 years.

The indications given on the working life cannot be interpreted as a guarantee given by the producer or Assessment Body, but are to be regarded only as a means for choosing the right products in relation to the expected economically reasonable working life of the works.

3 Performance of the product and references to the methods used for its assessment

Characteristic	Assessment of characteristic
3.1 Mechanical resistance and stability*) (BWR1)	
Tensile strength Threaded rods made of carbon steel	Characteristic value $f_{\text{tens,k}}$: d = 16,0 mm: 100 kN d = 20,0 mm: 160 kN
Insertion moment	Ratio of the characteristic torsional strength to the mean insertion moment: $f_{\text{tor,k}} / R_{\text{tor,mean}} \geq 1,5$
Torsional strength Threaded rods made of carbon steel	Characteristic value $f_{\text{tor,k}}$: d = 16,0 mm: 200 Nm d = 20,0 mm: 600 Nm
3.2 Safety in case of fire (BWR2)	
Reaction to fire	The screws are made from steel classified as performance class A1 of the characteristic reaction to fire, in accordance with the provisions of Commission Delegated Regulation 2016/364 and EC decision 96/603/EC, amended by EC Decision 2000/605/EC.
3.3 Safety in use (BWR4)	See aspects covered by BWR1
3.4 General aspects related to the performance of the product	The threaded rods have been assessed as having satisfactory durability and serviceability when used in timber structures using the timber species described in Eurocode 5 and subject to the conditions defined by service classes 1 and 2
Identification	See Annex A

*) See additional information in section 3.5 – 3.7

3.5 Mechanical resistance and stability

The load-carrying capacities for SFS WB-T threaded rods are applicable to the wood-based materials mentioned in paragraph 1 even though the term timber has been used in the following.

The characteristic lateral load-carrying capacities and the characteristic axial withdrawal capacities of SFS WB-T threaded rods should be used for designs in accordance with Eurocode 5 or an appropriate national code.

Penetration length must be $\ell_{ef} \geq 4 \cdot d$, where d is the outer thread diameter of the threaded rod.

European Technical Assessments for structural members or wood-based panels must be considered where applicable.

Reductions in the cross-sectional area caused by SFS WB-T threaded rods shall be taken into account in the member strength verification both, in the tensile and compressive area of members. Here, the drill hole diameter should be considered in the member strength verification.

Lateral load-carrying capacity

The characteristic lateral load-carrying capacity of SFS WB-T threaded rods shall be calculated according to EN 1995-1-1 (Eurocode 5) using the outer thread diameter d as the nominal diameter of the rod. The contribution from the rope effect may be considered.

The characteristic yield moment of SFS WB-T threaded rods shall be assumed as:

$$\begin{aligned} d = 16 \text{ mm:} & \quad M_{y,k} = 220 \quad \text{Nm} \\ d = 20 \text{ mm:} & \quad M_{y,k} = 390 \quad \text{Nm} \end{aligned}$$

where

d outer thread diameter

The embedding strength for threaded rods in pre-drilled holes arranged at an angle between rod axis and grain direction, $0^\circ \leq \alpha \leq 90^\circ$ is:

$$f_{h,k} = \frac{0,082 \cdot \rho_k \cdot (1 - 0,01 \cdot d)}{(2,5 \cdot \cos^2 \alpha + \sin^2 \alpha) \cdot (k_{90} \cdot \sin^2 \varepsilon + \cos^2 \varepsilon)} \quad [\text{N/mm}^2]$$

Where

- ρ_k characteristic timber density [kg/m^3];
- d outer thread diameter [mm];
- α angle between rod axis and grain direction;
- ε angle between force and grain direction;
- k_{90} according to equation (8.33) in EN 1995-1-1.

The embedding strength for rods arranged parallel to the plane of cross laminated timber, independent of the angle

between rod axis and grain direction, $0^\circ \leq \alpha \leq 90^\circ$, shall be calculated from:

$$f_{h,k} = 20 \cdot d^{-0,5} \quad [\text{N/mm}^2]$$

unless otherwise specified in the technical specification (ETA or hEN) for the cross laminated timber.

Where

d outer thread diameter [mm]

The embedding strength for threaded rods in the plane surface of cross laminated timber should be assumed as for solid timber based on the characteristic density of the outer layer. The angle between force and grain direction of the outer layer should be taken into account.

The direction of the lateral force shall be perpendicular to the rod axis and parallel to the plane surface of the cross laminated timber.

For laterally loaded rods, the rules for multiple fastener connections in EN 1995-1-1, 8.5.1.1 (4) should be applied.

Axial withdrawal capacity

The characteristic axial withdrawal capacity of threaded rods at an angle of $30^\circ \leq \alpha \leq 90^\circ$ to the grain in solid timber, glued laminated timber, cross-laminated timber members or laminated veneer lumber members shall be calculated according to EN 1995-1-1:2008 from:

$$F_{ax,\alpha,Rk} = n_{ef} \cdot k_{ax} \cdot f_{ax,k} \cdot d \cdot \ell_{ef} \cdot \left(\frac{\rho_k}{350} \right)^{0,8} \quad [\text{N}]$$

Where

- $F_{ax,\alpha,Rk}$ characteristic withdrawal capacity of the group of rods at an angle α to the grain [N]
- n_{ef} effective number of rods according to EN 1995-1-1:2008
- k_{ax} Factor, taking into account the angle between rod axis and grain direction
 $k_{ax} = 1,0$ for $45^\circ \leq \alpha < 90^\circ$
 $k_{ax} = 0,3 + \frac{0,7 \cdot \alpha}{45^\circ}$ for $30^\circ \leq \alpha < 45^\circ$
- $f_{ax,k}$ Characteristic withdrawal parameter
 $f_{ax,k} = 9,0 \text{ N/mm}^2$
- d outer thread diameter [mm]
- ℓ_{ef} Penetration length of the threaded part according to EN 1995-1-1 [mm];
- α Angle between grain and rod axis ($\alpha \geq 30^\circ$)
- ρ_k Characteristic density [kg/m^3]

For rods penetrating more than one layer of cross laminated timber, the different layers may be taken into account proportionally.

The axial withdrawal capacity for rods arranged parallel to the plane of cross laminated timber, independent of

the angle between rod axis and grain direction,

$0^\circ \leq \alpha \leq 90^\circ$, may be calculated from:

$$F_{ax,Rk} = 20 \cdot d^{0,8} \cdot \ell_{ef}^{0,9} \quad [N]$$

The axial withdrawal capacity is limited by the tensile or compressive capacity of the threaded rod.

For axially loaded rods in tension, where the external force is parallel to the rod axes, the rules in EN 1995-1-1, 8.7.2 (8) should be applied.

Note: For rods as tensile or compression reinforcement or inclined rods as fasteners in mechanically jointed beams or in shear reinforcements, $n_{ef} = n$.

Tensile capacity

The characteristic tensile capacity $f_{tens,k}$ of SFS WB-T threaded rods made of carbon steel is:

$$d = 16 \text{ mm}: \quad 100 \text{ kN}$$

$$d = 20 \text{ mm}: \quad 160 \text{ kN}$$

Compressive capacity

The characteristic compressive capacity $F_{ax,Rk}$ of SFS WB-T threaded rods embedded in timber shall be calculated from:

$$F_{ax,Rd} = \min \left\{ k_{ax} \cdot f_{ax,d} \cdot d \cdot \ell_{ef} \cdot \left(\frac{\rho_k}{350} \right)^{0,8}; \frac{\kappa_c \cdot N_{pl,k}}{\gamma_{M1}} \right\} \quad [N]$$

where

$$\kappa_c = \begin{cases} 1 & \text{for } \bar{\lambda}_k \leq 0,2 \\ \frac{1}{k + \sqrt{k^2 - \bar{\lambda}_k^2}} & \text{for } \bar{\lambda}_k > 0,2 \end{cases}$$

$$k = 0,5 \cdot \left[1 + 0,49 \cdot (\bar{\lambda}_k - 0,2) + \bar{\lambda}_k^2 \right]$$

The relative slenderness ratio shall be calculated from:

$$\bar{\lambda}_k = \sqrt{\frac{N_{pl,k}}{N_{ki,k}}}$$

Where

$$N_{pl,k} = \pi \cdot \frac{d_1^2}{4} \cdot f_{y,k} \quad [N]$$

is the characteristic value for the axial capacity in case of plastic analysis referred to the inner thread cross section.

Characteristic yield strength for SFS WB-T threaded rods:

$$f_{y,k} = 800 \text{ [N/mm}^2\text{]} \text{ for } d = 16 \text{ mm}$$

$$f_{y,k} = 700 \text{ [N/mm}^2\text{]} \text{ for } d = 20 \text{ mm}$$

Characteristic ideal elastic buckling load:

$$N_{ki,k} = \sqrt{c_h \cdot E_s \cdot I_s} \quad [N]$$

Elastic foundation of the rod:

$$c_h = (0,19 + 0,012 \cdot d) \cdot \rho_k \cdot \left(\frac{\alpha}{180^\circ} + 0,5 \right) \quad [N/mm^2]$$

for rods in cross-laminated timber, the most unfavourable combination of α and ρ_k governs;

Modulus of elasticity:

$$E_s = 210000 \quad [N/mm^2]$$

$$\rho_k = \text{characteristic density} \quad [kg/m^3]$$

Second moment of area:

$$I_s = \frac{\pi}{64} \cdot d_1^4 \quad [mm^4]$$

$$d_1 = \text{inner thread diameter} \quad [mm]$$

$$\alpha = \text{angle between screw axis and grain direction} \quad [^\circ]$$

Note: When determining design values of the compressive capacity it should be considered that $f_{ax,d}$ is to be calculated using k_{mod} and γ_M for timber according to EN 1995 while $N_{pl,d}$ is calculated using $\gamma_{M,1}$ for steel buckling according to EN 1993.

Combined laterally and axially loaded threaded rods

For connections subjected to a combination of axial and lateral load, the following expression should be satisfied:

$$\left(\frac{F_{ax,Ed}}{F_{ax,Rd}} \right)^2 + \left(\frac{F_{la,Ed}}{F_{la,Rd}} \right)^2 \leq 1$$

where

$F_{ax,Ed}$ axial design load of the threaded rod

$F_{la,Ed}$ lateral design load of the threaded rod

$F_{ax,Rd}$ design load-carrying capacity of an axially loaded threaded rod

$F_{la,Rd}$ design load-carrying capacity of a laterally loaded threaded rod

Slip modulus

The axial slip modulus K_{ser} of a rod for the serviceability limit state should be taken independent of angle α to the grain as:

$$C = K_{ser} = 25 \cdot d \cdot \ell_{ef} \quad [N/mm]$$

Where

d outer thread diameter [mm]

ℓ_{ef} penetration length in the structural member [mm]

Compression reinforcement

See annex B.

Tensile reinforcement

See annex C.

Shear reinforcement

See annex D.

3.6 Related aspects of serviceability

3.6.1 Corrosion protection in service class 1 and 2

The SFS WB-T threaded rods are produced from carbon steel wire. They are zinc coated (minimum 5 µm) and blue passivated.

3.7 General aspects related to the intended use of the product

The installation shall be carried out in accordance with Eurocode 5 or an appropriate national code unless otherwise is defined in the following. Instructions from SFS intec AG (Heerbrugg) should be considered for installation.

The threaded rods are used for connections in load bearing members of solid timber (softwood), glued laminated timber (softwood), cross-laminated timber, and laminated veneer lumber (softwood) or similar glued members.

The threaded rods may be used for connections in load bearing timber structures with structural members according to an associated European Technical Assessment, if according to the associated European Technical Assessment of the structural member a connection in load bearing timber structures with screws according to a European Technical Assessment is allowed.

SFS WB-T threaded rods are also used as tensile or compressive reinforcement perpendicular to the grain or as shear reinforcement in softwood members.

A minimum of two threaded rods should be used for connections in load bearing timber structures. A single rod may be used in structural connections if the penetration length of the rod is at least $20 \cdot d$ and the rod is only axially loaded. If the rod is used to connect wood-based members the load-bearing capacity of the single rod in this case shall be reduced by 50 %. If the rod is used as tensile or compressive reinforcement of timber structures perpendicular to the grain no reduction of the load-bearing capacity of the rod is required. This also applies for other situations specified in National Annexes to EN 1995-1-1.

The minimum penetration depth in structural members made of solid, glued or cross-laminated timber is $4 \cdot d$.

For structural members according to European Technical Assessments the terms of the European Technical Assessments must be considered.

The rods shall be driven into softwood after pre-drilling. The drill hole diameters are:

Outer thread diameter	Drill hole diameter in softwood
16,0	13,0
20,0	16,0

Only the equipment prescribed by SFS intec AG (Heerbrugg) shall be used for driving the rods.

4 Attestation and verification of constancy of performance (AVCP)

4.1 AVCP system

According to the decision 97/176/EC of the European Commission¹, as amended, the system(s) of assessment and verification of constancy of performance (see Annex V to Regulation (EU) No 305/2011) is 3.

5 Technical details necessary for the implementation of the AVCP system, as foreseen in the applicable EAD

Technical details necessary for the implementation of the AVCP system are laid down in the control plan deposited at ETA-Danmark prior to CE marking.

Issued in Copenhagen 2022-06-01 on



Thomas Bruun
Managing Director, ETA-Danmark

Annex A

Drawings, designation and material specification of SFS WB-T threaded rods

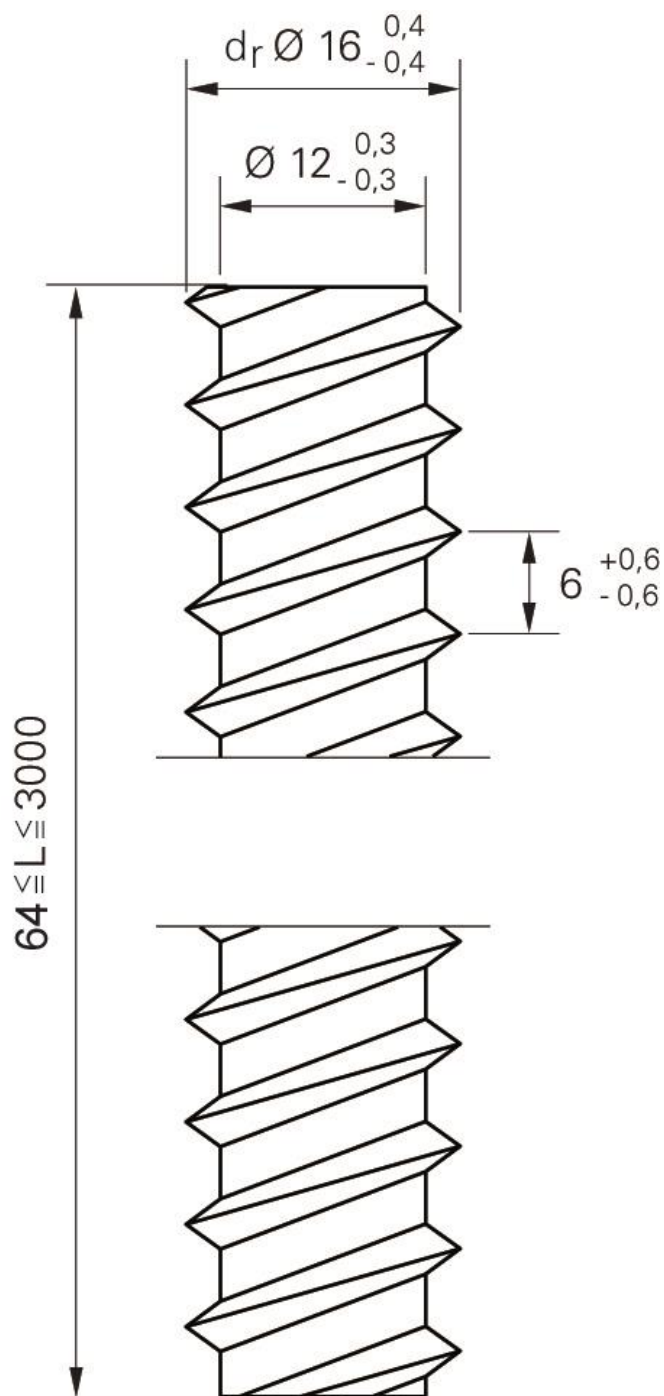

Length may be changed by cutting the threaded rod

WB-T-16

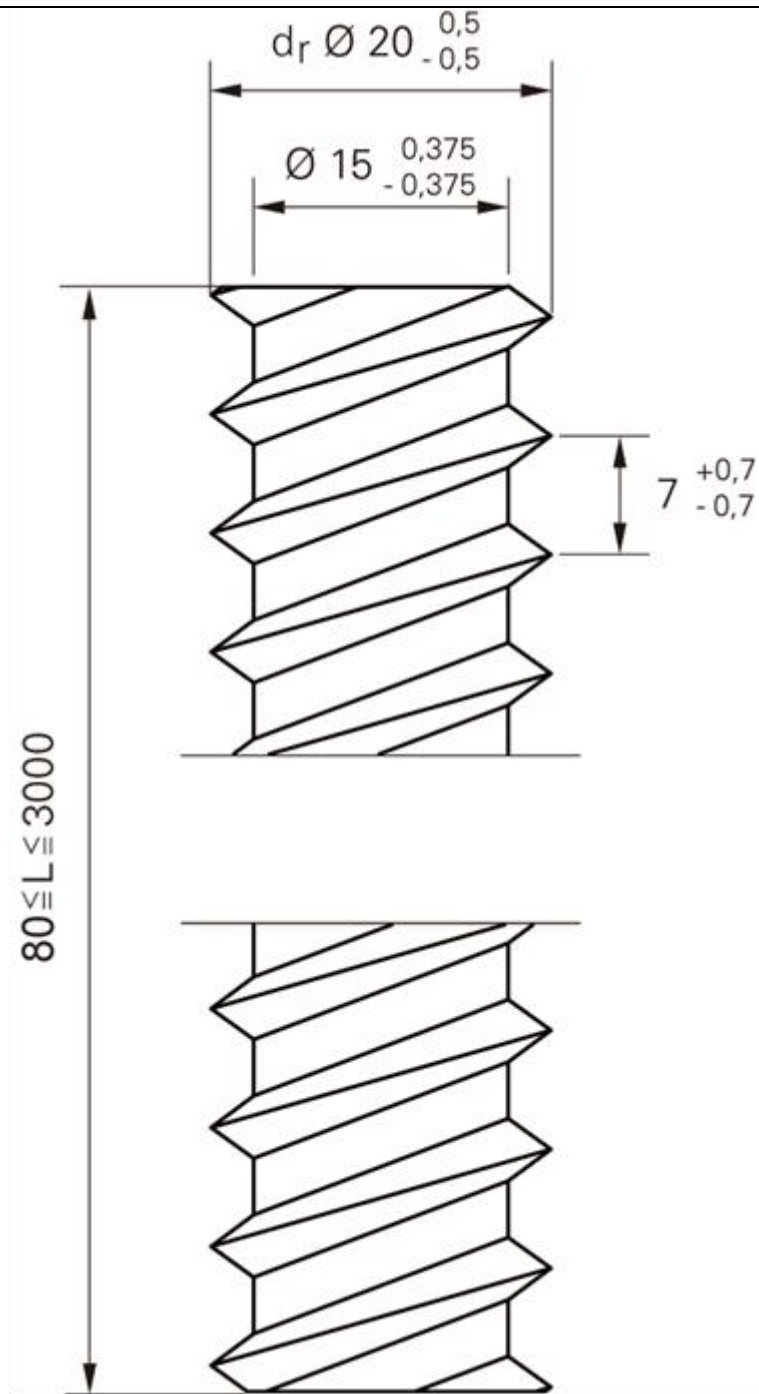

Length may be changed by cutting the threaded rod

WB-T-20

Annex B**Compression reinforcement**

SFS WB-T threaded rods with a full thread may be used for reinforcement of timber members with compression stresses at an angle α to the grain of $45^\circ \leq \alpha \leq 90^\circ$. The compression force must be evenly distributed over all rods. An appropriate steel plate as intermediate layer between timber member and support has to be installed. The rods have to be driven into the timber member flush with the surface to provide both direct contact with the steel plate and direct contact between steel plate and timber.

The characteristic load-carrying capacity for a contact area with rods with a full thread at an angle α to the grain of $45^\circ \leq \alpha \leq 90^\circ$ shall be calculated from:

$$F_{90,Rd} = \min \left\{ \begin{array}{l} k_{c,90} \cdot B \cdot \ell_{ef,1} \cdot f_{c,90,d} + n \cdot F_{ax,Rd} \\ B \cdot \ell_{ef,2} \cdot f_{c,90,d} \end{array} \right. \quad (B.1)$$

Where

- $F_{90,Rd}$ Design load-carrying capacity of reinforced contact area [N]
- $k_{c,90}$ factor for compression perpendicular to the grain according to EN 1995-1-1
- B bearing width [mm]
- $\ell_{ef,1}$ effective length of contact area according to EN 1995-1-1 [mm]
- $f_{c,90,k}$ characteristic compressive strength perpendicular to the grain [N/mm²]
- n number of reinforcement rods, $n = n_0 \cdot n_{90}$
- n_0 number of reinforcement rods arranged in a row parallel to the grain
- n_{90} number of reinforcement rods arranged in a row perpendicular to the grain
- $F_{ax,Rd}$ Design compressive capacity [N], see page 4
- $\ell_{ef,2}$ effective distribution length in the plane of the rod ends [mm]
- $\ell_{ef,2} = \ell_{ef} + (n_0 - 1) \cdot a_1 + \min(\ell_{ef}; a_{3,c})$
for end-bearings [mm]
- $\ell_{ef,2} = 2 \cdot \ell_{ef} + (n_0 - 1) \cdot a_1$ for centre-bearings [mm]
- ℓ_{ef} penetration length [mm]
- a_1 spacing parallel to the grain [mm]
- $a_{3,c}$ end distance [mm]

If rods are driven into the member from top and bottom and the rods are overlapping at least $10 \cdot d$, i.e. $\ell_{ef,top} + \ell_{ef,bottom} \geq H + 10 \cdot d$, the second condition in equation (B.1) may be disregarded.

If rods are continuous from top to bottom of the timber member, the design resistance of a reinforced contact area is:



$$F_{90,Rd} = n \cdot \kappa_c \cdot N_{pl,d} \quad (B.2)$$

For continuous rods, the difference between the loads introduced from top and bottom, respectively, should fulfil the following condition:

$$\Delta F_{90,Ed} \leq n \cdot f_{ax,d} \cdot d \cdot \ell_{ef} \quad (B.3)$$

Reinforced centre-bearing

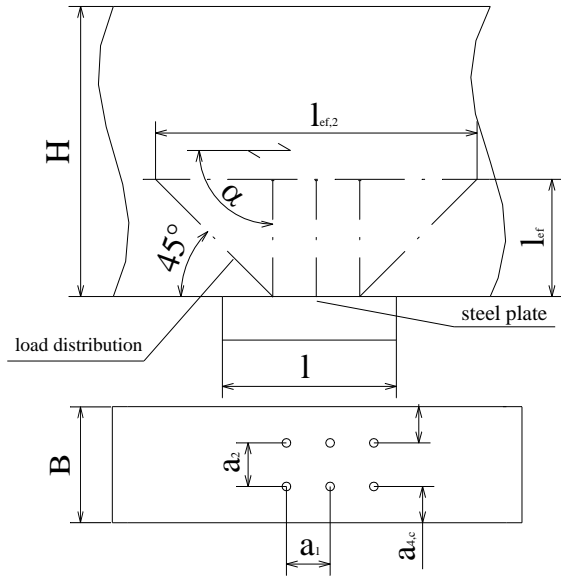

- H component height [mm]
- B bearing width [mm]
- l_{ef} penetration length [mm]
- $l_{ef,2}$ effective distribution length in the plane of the rod ends [mm]
 $= 2 \cdot l_{ef} + (n_0 - 1) \cdot a_1$ for centre-bearings

-  grain direction
-  rod axis
- $45^\circ \leq \alpha \leq 90^\circ$



Reinforced end-bearing

- H component height [mm]
- B bearing width [mm]
- l_{ef} penetration length [mm]
- $l_{ef,2}$ effective distribution length in the plane of the rod ends [mm]
 $= l_{ef} + (n_0 - 1) \cdot a_1 + \min(l_{ef}; a_{3,c})$ for end-bearings

-  grain direction
-  rod axis
- $45^\circ \leq \alpha \leq 90^\circ$

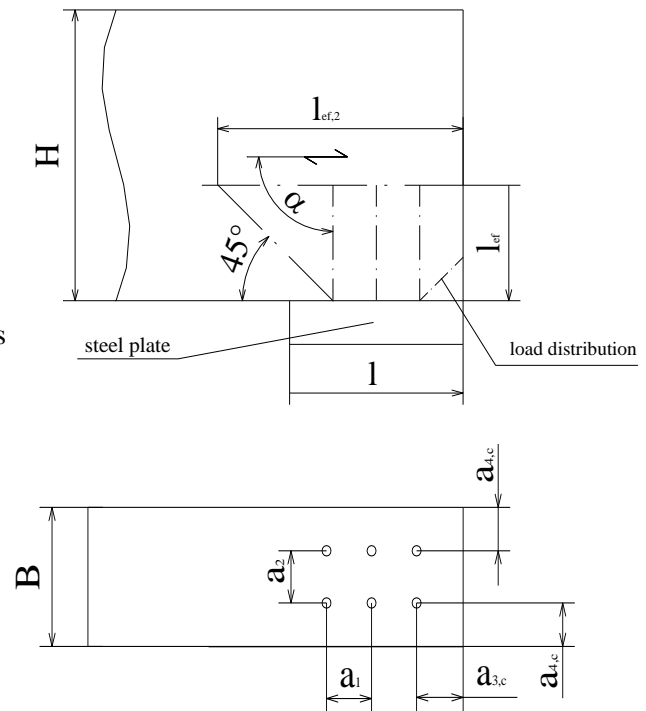

- $a_1 \geq 5 \cdot d$
- $a_2 \geq 4 \cdot d$
- $a_{3,c} \geq 7 \cdot d$
- $a_{4,c} \geq 3 \cdot d$
- $a_1 \cdot a_2 \geq 25 \cdot d^2$

The rods must be flush with the surface of the structural timber member.

Annex C Tensile reinforcement perpendicular to grain

Unless specified otherwise in national provisions that apply at the installation site, the axial capacity of a reinforcement of a timber member loaded by a connection force perpendicular to the grain shall fulfil the following condition:

$$\frac{[1 - 3 \cdot \alpha^2 + 2 \cdot \alpha^3] \cdot F_{90,d}}{F_{ax,Rd}} \leq 1$$

Where

$F_{90,d}$ Design value of the force component perpendicular to the grain [N],

$\alpha = a/h$

$h =$ member depth [mm]

$F_{ax,Rd}$ Minimum of the design values of the withdrawal capacity and the tensile capacity of the reinforcing threaded rods where ℓ_{ef} is the smaller value of the penetration depth below or above the potential crack

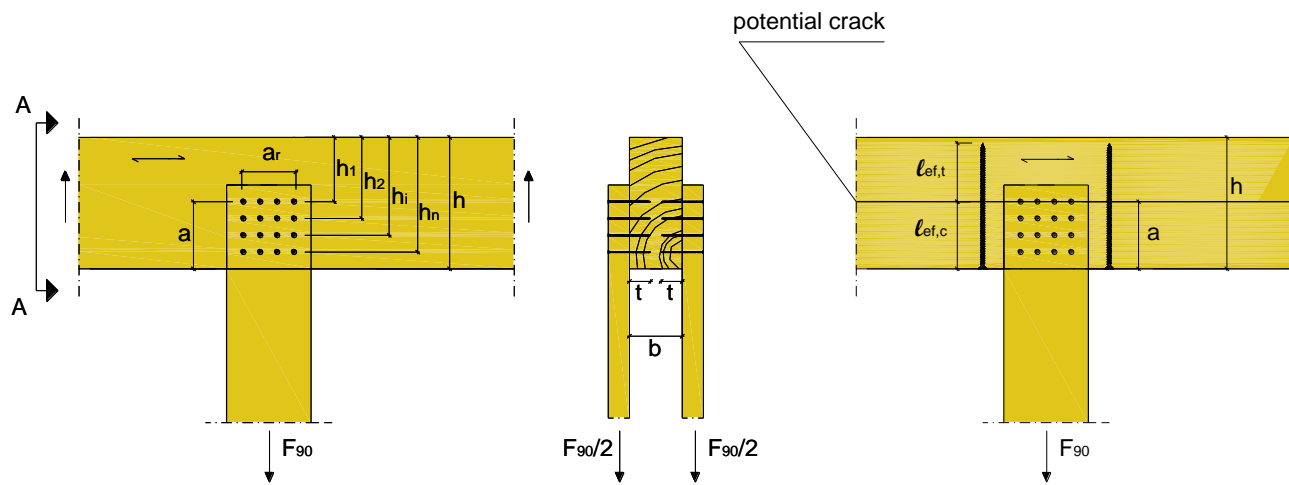

Unless specified otherwise in national provisions that apply at the installation site, the axial capacity of a reinforcement of a notched beam support shall fulfil the following condition:

$$\frac{1,3 \cdot V_d \cdot [3 \cdot (1 - \alpha)^2 - 2 \cdot (1 - \alpha)^3]}{F_{ax,Rd}} \leq 1$$

Where

V_d Design value of the shear force [N],

$\alpha = h/h_e$

$h =$ member depth [mm]

$F_{ax,Rd}$ Minimum of the design values of the withdrawal capacity and the tensile capacity of the reinforcing threaded rods where ℓ_{ef} is the smaller value of the penetration depth below or above the potential crack [N]

The minimum spacing a_2 of threaded rods used as reinforcement of a notched beam support is $a_2 = 3 \cdot d$, the minimum end or edge distance is $a_{3,c} = 2,5 \cdot d$ or $a_{4,c} = 3 \cdot d$.

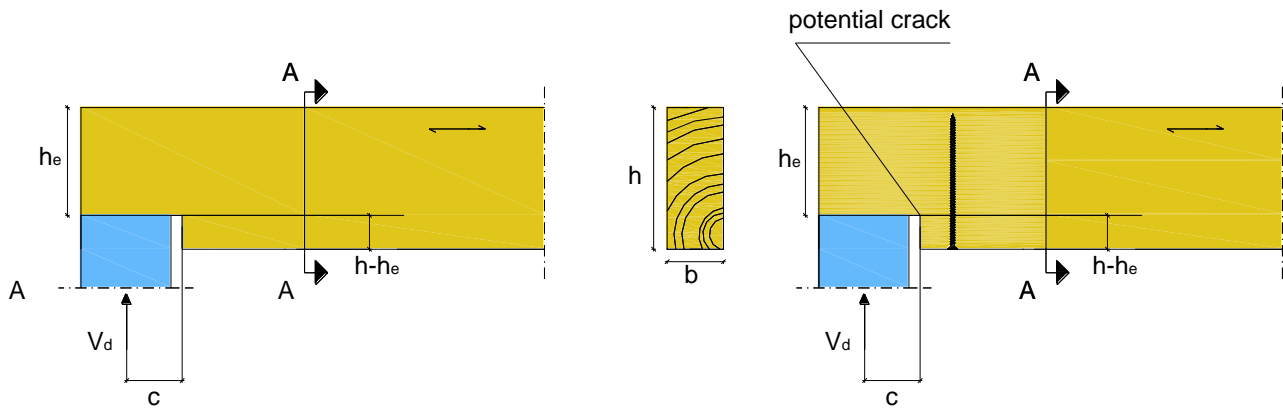

Unless specified otherwise in national provisions that apply at the installation site, the axial capacity of a reinforcement of a hole in a beam shall fulfil the following condition:

$$\frac{F_{t,V,d} + F_{t,M,d}}{F_{ax,Rd}} \leq 1$$

Where

$F_{t,V,d}$ Design value of the force perpendicular to the grain due to shear force [N]:

$$F_{t,V,d} = \frac{V_d \cdot h_d}{4 \cdot h} \cdot \left[3 - \frac{h_d^2}{h^2} \right]$$

V_d Design value of the member shear force at the hole end [N],

h = member depth [mm]

h_d = hole depth for rectangular holes [mm]

h_d = 70 % of hole diameter for circular holes [mm]

$F_{t,M,d}$ Design value of the force perpendicular to the grain due to bending moment [N]:

$$F_{t,M,d} = 0,008 \cdot \frac{M_d}{h_r}$$

M_d Design value of the member bending moment at the hole end [Nmm],

h_r = $\min(h_{ro}; h_{ru})$ for rectangular holes [mm]

h_r = $\min(h_{ro}; h_{ru}) + 0,15 \cdot h_d$ for circular holes [mm]

$F_{ax,Rd}$ Minimum of the design values of the withdrawal capacity and the tensile capacity of the reinforcing threaded rods where ℓ_{ef} is the smaller value of the penetration depth below or above the potential crack [N].

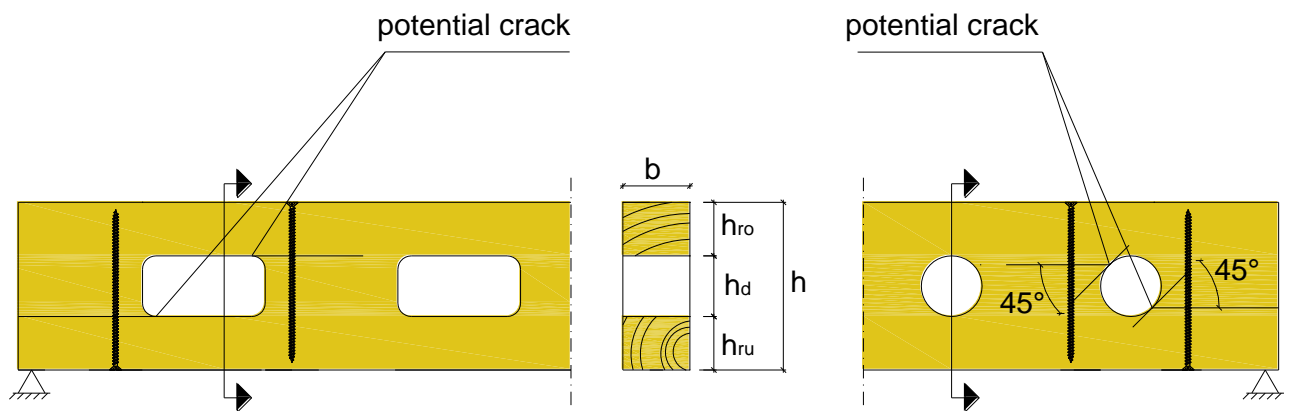

Apart from the reinforcement with rods, strength verification is required for the shear strength of the timber member in the vicinity of the hole.

Annex D Shear reinforcement

Unless specified otherwise in national provisions that apply at the installation site, the shear stress in reinforced areas of timber members with a stress component parallel to the grain shall fulfil the following condition:

$$\tau_d \leq \frac{f_{v,d} \cdot k_\tau}{\eta_H}$$

Where:

τ_d is the design shear stress disregarding the reinforcement [N/mm²];

$f_{v,d}$ is the design shear strength [N/mm²];

$$k_\tau = 1 - 0,46 \cdot \sigma_{90,d} - 0,052 \cdot \sigma_{90,d}^2$$

$\sigma_{90,d}$ is the design stress perpendicular to the grain (negative value for compression) [N/mm²];

$$\sigma_{90,d} = \frac{F_{ax,d}}{\sqrt{2} \cdot b \cdot a_1}$$

$$F_{ax,d} = \frac{\sqrt{2} \cdot (1 - \eta_H) \cdot V_d \cdot a_1}{h} \text{ [N]}$$

$$\eta_H = \frac{G \cdot b}{G \cdot b + \frac{1}{2 \cdot \sqrt{2} \left(\frac{6}{\pi \cdot d \cdot h \cdot k_{ax}} + \frac{a_1}{EA_S} \right)}}$$

V_d is the design shear force [N];

G is the shear modulus of the timber member, $G = 650$ [N/mm²],

b is the width of the timber member [mm],

d is the outer thread diameter [mm],

h is the depth of the timber member [mm],

k_{ax} is the connection stiffness between rod and timber member per unit area of the cylindrical area of the outer thread [N/mm³],

$$k_{ax} = 5 \text{ N/mm}^3 \text{ for threaded rods,}$$

a_1 is the spacing parallel to the grain of the rods arranged in one row [mm],

EA_S is the axial stiffness of one rod [N],

$$EA_S = \frac{E \cdot \pi \cdot d_1^2}{4} = 165.000 d_1^2,$$

d_1 is the inner thread diameter of the rod [mm],

$$d_1 = 12 \text{ mm for threaded rods } d = 16 \text{ mm, } d_1 = 15 \text{ mm for threaded rods } d = 20 \text{ mm.}$$

The axial capacity of a threaded rod shall fulfil the following condition:

$$\frac{F_{ax,d}}{F_{ax,Rd}} \leq 1$$

where: $F_{ax,Rd}$ Minimum of the design values of the withdrawal capacity and the tensile capacity of the reinforcing rods [N]. The effective penetration length is 50 % of the threaded length.

Outside reinforced areas (shaded area in Figure D.1) the shear design shall fulfil the conditions for unreinforced members.

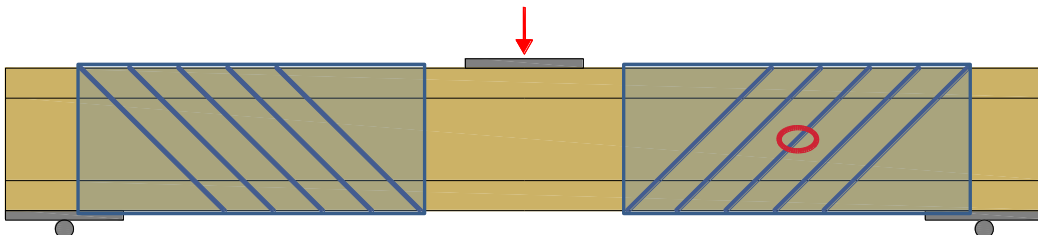

Figure D.1: Timber member with shear reinforcement; shaded areas: reinforced areas